

BHT FB 400°

Aşırı Yüksek Isı Rulmanları



6000 SERISI

Parça	İç Çap (B)	Dış (D)	Genişlik (W)	Devir Sayı.RPM	Statik Yük, 400°C 'de kN	Statik Yük, 20°C 'de kN
6000 BHT FB 400°	10	26	8	90	1,35	1,96
6001 BHT FB 400°	12	28	8	85	1,63	2,36
6002 BHT FB 400°	15	32	9	80	1,97	2,85
6003 BHT FB 400°	17	35	10	75	2,24	3,25
6004 BHT FB 400°	20	42	12	70	3,45	5,00
6005 BHT FB 400°	25	47	12	65	4,03	5,85
6006 BHT FB 400°	30	55	13	60	5,52	8,00
6007 BHT FB 400°	35	62	14	55	7,17	10,4
6008 BHT FB 400°	40	68	15	50	8,14	11,8
6009 BHT FB 400°	45	75	16	45	9,86	14,3
6010 BHT FB 400°	50	80	16	40	10,76	15,6
6011 BHT FB 400°	55	90	18	40	14,62	21,2
6012 BHT FB 400°	60	95	18	40	16,00	23,2
6013 BHT FB 400°	65	100	18	40	17,24	25,0
6014 BHT FB 400°	70	110	20	40	21,72	31,5
6015 BHT FB 400°	75	115	20	40	23,45	34,0

6200 SERISI

Parça	İç Çap (B)	Dış (D)	Genişlik (W)	Devir Sayı.RPM	Statik Yük, 400°C 'de kN	Statik Yük, 20°C 'de kN
6200 BHT FB 400°	10	30	9	90	1,79	2,60
6201 BHT FB 400°	12	32	10	85	2,14	3,10
6202 BHT FB 400°	15	35	11	80	2,59	3,75
6203 BHT FB 400°	17	40	12	75	3,28	4,75
6204 BHT FB 400°	20	47	14	70	4,52	6,55
6205 BHT FB 400°	25	52	15	65	5,52	8,00
6206 BHT FB 400°	30	62	16	60	7,72	11,2
6207 BHT FB 400°	35	72	17	55	10,55	15,3
6208 BHT FB 400°	40	80	18	50	12,41	18,0
6209 BHT FB 400°	45	85	19	45	14,07	20,4
6210 BHT FB 400°	50	90	20	40	16,55	24,0
6211 BHT FB 400°	55	100	21	40	20,00	29,0
6212 BHT FB 400°	60	110	22	40	24,83	36,0
6213 BHT FB 400°	65	120	23	40	28,62	41,5
6214 BHT FB 400°	70	125	24	40	30,34	44,0
6215 BHT FB 400°	75	130	25	40	33,80	49,0

6300 SERISI

Parça	İç Çap (B)	Dış (D)	Genişlik (W)	Devir Sayı.RPM	Statik Yük, 400°C 'de kN	Statik Yük, 20°C 'de kN
6300 BHT FB 400°	10	35	11	90	2,38	3,45
6301 BHT FB 400°	12	37	12	85	2,86	4,15
6302 BHT FB 400°	15	42	13	80	3,72	5,40
6303 BHT FB 400°	17	47	14	75	4,52	6,55
6304 BHT FB 400°	20	52	15	70	5,86	8,50
6305 BHT FB 400°	25	62	17	65	7,98	11,4
6306 BHT FB 400°	30	72	19	60	11,24	16,3
6307 BHT FB 400°	35	80	21	55	13,10	19,0
6308 BHT FB 400°	40	90	23	50	17,20	25,0
6309 BHT FB 400°	45	100	25	45	22,00	32,0
6310 BHT FB 400°	50	110	27	40	26,20	38,0
6311 BHT FB 400°	55	120	29	40	32,70	47,5
6312 BHT FB 400°	60	130	31	40	35,90	52,0
6313 BHT FB 400°	65	140	33	40	41,38	60,0
6314 BHT FB 400°	70	150	35	40	46,90	68,0
6315 BHT FB 400°	75	160	37	40	52,76	76,5

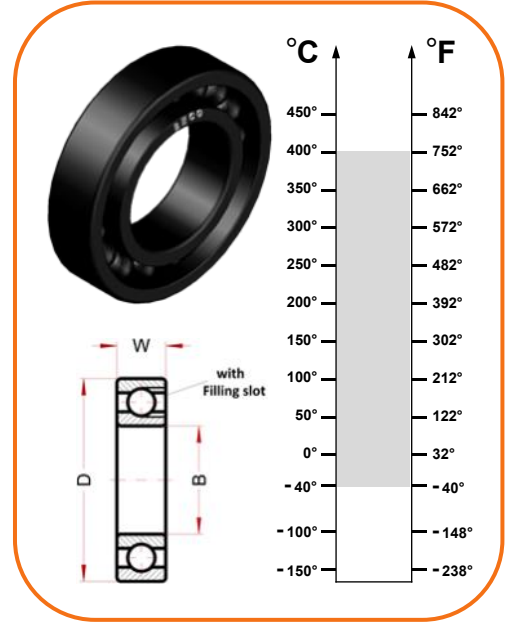

Teknik Özellikleri:

- Rulman Malzemesi: AISI 52100 (Krom)
- Rulmanın tüm Çelik Parçaları Manganez Fosfat Kaplı
- Radyal Boşluk 4xC5
- Açık Tip Rulman
- Yağlama Yapılmamıştır
- İsteğe Göre Yağlama
- Tekrar Yağlama İhtiyacı olan Rulman

Kullanım Alanları:

- Boya Fırınları
- Çelik Sanayi
- Seramik Fırınları
- Endüstriyel Taşıyıcıları, Tuğla Fırınlarının Taşıyıcıları

BECCO

12100 Cuneo - Italy
phone: 0039 0171 66883
fax: 0039 0171 648913
www.becoitalia.biz

■ BİRLİK RULMAN

