

BHTS 2RS C4 VT 220°

Ležaji za visoke temperature



SERIJA 6000

| Opis | Ønot. (B) | Øzun. (D) | širina (W) | Hitrost, VRT/MIN | Statič.nosil. kN pri 220°C | Statič.nosil. kN pri 20°C |
|--------------------------|-----------|-----------|------------|------------------|----------------------------|---------------------------|
| 6000 BHTS 2RS C4 VT 220° | 10 | 26 | 8 | 4200 | 1,50 | 1,96 |
| 6001 BHTS 2RS C4 VT 220° | 12 | 28 | 8 | 4060 | 1,79 | 2,36 |
| 6002 BHTS 2RS C4 VT 220° | 15 | 32 | 9 | 3920 | 2,13 | 2,85 |
| 6003 BHTS 2RS C4 VT 220° | 17 | 35 | 10 | 3780 | 2,46 | 3,25 |
| 6004 BHTS 2RS C4 VT 220° | 20 | 42 | 12 | 3640 | 3,83 | 5,00 |
| 6005 BHTS 2RS C4 VT 220° | 25 | 47 | 12 | 3360 | 4,42 | 5,85 |
| 6006 BHTS 2RS C4 VT 220° | 30 | 55 | 13 | 3080 | 6,11 | 8,00 |
| 6007 BHTS 2RS C4 VT 220° | 35 | 62 | 14 | 2800 | 7,91 | 10,4 |
| 6008 BHTS 2RS C4 VT 220° | 40 | 68 | 15 | 2520 | 9,01 | 11,8 |
| 6009 BHTS 2RS C4 VT 220° | 45 | 75 | 16 | 2240 | 10,8 | 14,3 |
| 6010 BHTS 2RS C4 VT 220° | 50 | 80 | 16 | 1960 | 11,9 | 15,6 |
| 6011 BHTS 2RS C4 VT 220° | 55 | 90 | 18 | 1680 | 16,1 | 21,2 |
| 6012 BHTS 2RS C4 VT 220° | 60 | 95 | 18 | 1400 | 17,1 | 23,2 |
| 6013 BHTS 2RS C4 VT 220° | 65 | 100 | 18 | 1260 | 18,1 | 25,0 |
| 6014 BHTS 2RS C4 VT 220° | 70 | 110 | 20 | 1120 | 22,8 | 31,5 |
| 6015 BHTS 2RS C4 VT 220° | 75 | 115 | 20 | 980 | 24,0 | 34,0 |
| 6016 BHTS 2RS C4 VT 220° | 80 | 125 | 22 | 840 | 28,8 | 40,0 |
| 6017 BHTS 2RS C4 VT 220° | 85 | 130 | 22 | 700 | 30,9 | 42,9 |
| 6018 BHTS 2RS C4 VT 220° | 90 | 140 | 24 | 630 | 36,0 | 49,9 |
| 6019 BHTS 2RS C4 VT 220° | 95 | 145 | 24 | 560 | 38,8 | 53,9 |
| 6020 BHTS 2RS C4 VT 220° | 100 | 160 | 24 | 490 | 38,8 | 53,9 |

SERIJA 6200

| Opis | Ønot. (B) | Øzun. (D) | širina (W) | Hitrost, VRT/MIN | Statič.nosil. kN pri 220°C | Statič.nosil. kN pri 20°C |
|--------------------------|-----------|-----------|------------|------------------|----------------------------|---------------------------|
| 6200 BHTS 2RS C4 VT 220° | 10 | 30 | 9 | 4060 | 1,96 | 2,60 |
| 6201 BHTS 2RS C4 VT 220° | 12 | 32 | 10 | 3920 | 2,38 | 3,10 |
| 6202 BHTS 2RS C4 VT 220° | 15 | 35 | 11 | 3780 | 2,81 | 3,75 |
| 6203 BHTS 2RS C4 VT 220° | 17 | 40 | 12 | 3640 | 3,57 | 4,75 |
| 6204 BHTS 2RS C4 VT 220° | 20 | 47 | 14 | 3360 | 5,02 | 6,55 |
| 6205 BHTS 2RS C4 VT 220° | 25 | 52 | 15 | 3080 | 6,12 | 8,00 |
| 6206 BHTS 2RS C4 VT 220° | 30 | 62 | 16 | 2800 | 8,50 | 11,2 |
| 6207 BHTS 2RS C4 VT 220° | 35 | 72 | 17 | 2520 | 11,6 | 15,3 |
| 6208 BHTS 2RS C4 VT 220° | 40 | 80 | 18 | 2240 | 13,7 | 18,0 |
| 6209 BHTS 2RS C4 VT 220° | 45 | 85 | 19 | 1960 | 15,5 | 20,4 |
| 6210 BHTS 2RS C4 VT 220° | 50 | 90 | 20 | 1680 | 18,3 | 24,0 |
| 6211 BHTS 2RS C4 VT 220° | 55 | 100 | 21 | 1400 | 22,1 | 29,0 |
| 6212 BHTS 2RS C4 VT 220° | 60 | 110 | 22 | 1260 | 27,5 | 36,0 |
| 6213 BHTS 2RS C4 VT 220° | 65 | 120 | 23 | 1120 | 31,7 | 41,5 |
| 6214 BHTS 2RS C4 VT 220° | 70 | 125 | 24 | 980 | 33,6 | 44,0 |
| 6215 BHTS 2RS C4 VT 220° | 75 | 130 | 25 | 840 | 37,4 | 49,0 |
| 6216 BHTS 2RS C4 VT 220° | 80 | 140 | 26 | 700 | 42,3 | 55,0 |
| 6217 BHTS 2RS C4 VT 220° | 85 | 150 | 28 | 630 | 49,2 | 64,0 |
| 6218 BHTS 2RS C4 VT 220° | 90 | 160 | 30 | 560 | 56,5 | 73,5 |
| 6219 BHTS 2RS C4 VT 220° | 95 | 170 | 32 | 490 | 62,7 | 81,5 |
| 6220 BHTS 2RS C4 VT 220° | 100 | 180 | 34 | 420 | 71,5 | 93,0 |

SERIJA 6300

| Opis | Ønot. (B) | Øzun. (D) | širina (W) | Hitrost, VRT/MIN | Statič.nosil. kN pri 220°C | Statič.nosil. kN pri 20°C |
|--------------------------|-----------|-----------|------------|------------------|----------------------------|---------------------------|
| 6300 BHTS 2RS C4 VT 220° | 10 | 35 | 11 | 3920 | 2,64 | 3,45 |
| 6301 BHTS 2RS C4 VT 220° | 12 | 37 | 12 | 3780 | 3,15 | 4,15 |
| 6302 BHTS 2RS C4 VT 220° | 15 | 42 | 13 | 3640 | 4,08 | 5,40 |
| 6303 BHTS 2RS C4 VT 220° | 17 | 47 | 14 | 3360 | 4,93 | 6,55 |
| 6304 BHTS 2RS C4 VT 220° | 20 | 52 | 15 | 3080 | 6,40 | 8,50 |
| 6305 BHTS 2RS C4 VT 220° | 25 | 62 | 17 | 2800 | 8,67 | 11,4 |
| 6306 BHTS 2RS C4 VT 220° | 30 | 72 | 19 | 2520 | 12,5 | 16,3 |
| 6307 BHTS 2RS C4 VT 220° | 35 | 80 | 21 | 2240 | 14,5 | 19,0 |
| 6308 BHTS 2RS C4 VT 220° | 40 | 90 | 23 | 1960 | 19,1 | 25,0 |
| 6309 BHTS 2RS C4 VT 220° | 45 | 100 | 25 | 1680 | 24,5 | 32,0 |
| 6310 BHTS 2RS C4 VT 220° | 50 | 110 | 27 | 1400 | 29,1 | 38,0 |
| 6311 BHTS 2RS C4 VT 220° | 55 | 120 | 29 | 1260 | 36,3 | 47,5 |
| 6312 BHTS 2RS C4 VT 220° | 60 | 130 | 31 | 1120 | 39,8 | 52,0 |
| 6313 BHTS 2RS C4 VT 220° | 65 | 140 | 33 | 980 | 45,9 | 60,0 |
| 6314 BHTS 2RS C4 VT 220° | 70 | 150 | 35 | 840 | 52,0 | 68,0 |
| 6315 BHTS 2RS C4 VT 220° | 75 | 160 | 37 | 700 | 58,5 | 76,5 |
| 6316 BHTS 2RS C4 VT 220° | 80 | 170 | 39 | 630 | 66,5 | 86,5 |
| 6317 BHTS 2RS C4 VT 220° | 85 | 180 | 41 | 560 | 74,2 | 96,5 |
| 6318 BHTS 2RS C4 VT 220° | 90 | 190 | 43 | 490 | 83,1 | 108 |
| 6319 BHTS 2RS C4 VT 220° | 95 | 200 | 45 | 420 | 90,7 | 118 |
| 6320 BHTS 2RS C4 VT 220° | 100 | 215 | 47 | 350 | 107,7 | 140 |

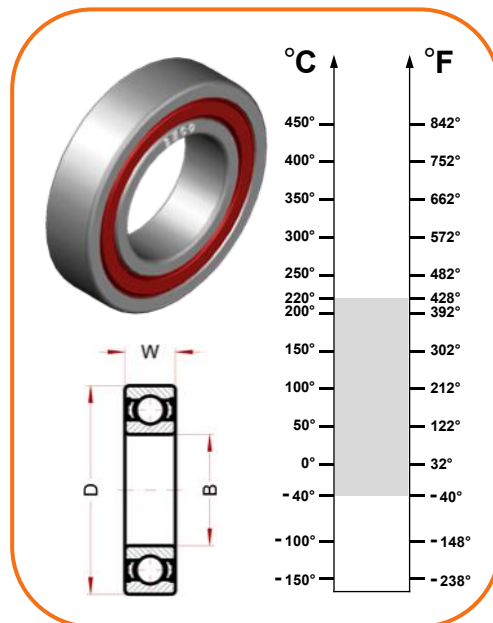

Tehnične karakteristike:

- Material ležaja: jeklo AISI 52100
- Radialna zračnost C4
- Gumi tesnilo 2RS Viton do 220°C (jekleno z gumi ustnico)
- Doživljenjsko namazano z brezsilikonsko mastjo na osnovi PTFE za temperature do 280°C (kapljišče nad 400°C)
- Ni potrebno dodatno mazanje

Področja uporabe:

- Viseči transporterji
- Industrijski ventilatorji
- Pakirni stroji, linije
- Jeklarska industrija
- Keramična industrija
- Papirna industrija

BECCO

12100 Cuneo - Italy

phone: 0039 0171 66883

fax: 0039 0171 648913

www.becoitalia.biz